

LIFAN

PARTS CATALOG

ENGINE 168F

E-1 曲轴箱组合 CRANKCASE ASSY

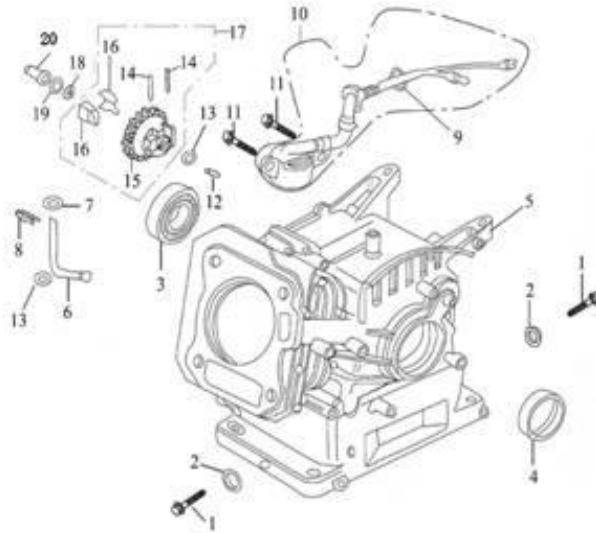

序号 S/N	零 部 件 代 号 Part No.	零 部 件 名 称	Description	数量 Quantity	备 注 Remark
1	11115/168F	放油螺塞	Drain plug	2	
2	11116/168F	放油螺塞垫圈	Washer	2	
3	GB/T276	轴承 6205	Bearing 6205	1	
4	11120/168F	曲轴油封组件	Oil seal, crankshaft	1	
5	11100	曲轴箱组合	Crankcase	1	
6	26111/168F	调速摆杆	Regulating sway bar	1	
7	26113/168F	调速摆杆垫片	Washer	1	
8	26112/168F	调速摆杆锁夹	Split pin	1	
9	GB/T6177	螺母 M10	Nut M10	1	
10	27400/168F	机油传感器组合	Oil sensor	1	
11	GB/T16674.2	螺栓 M6×14	Bolt M6×14	2	
12	25115/168F	调速轴	Regulating shaft	1	
13	25118/168F	调速从动齿轮垫片	Washer, driven gear	2	
14	25116/168F	飞块销	Pin	2	

E-1 曲轴箱组合 CRANKCASE ASSY

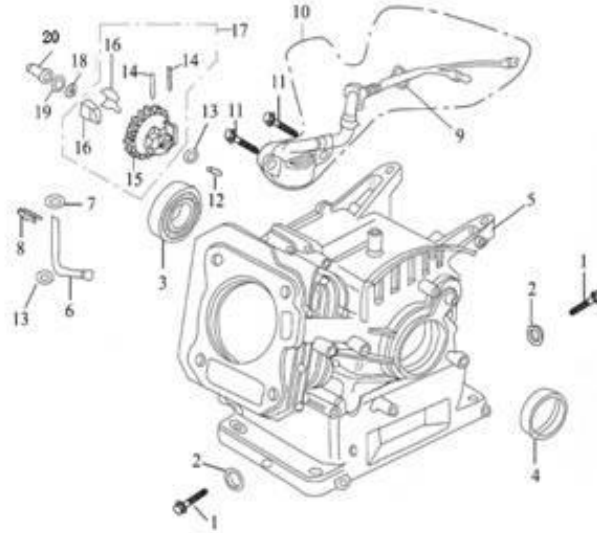

序号 S/N	零 部 件 代 号 Part No.	零 部 件 名 称	Description	数 量 Quantity	备 注 Remark
15	25111/168F	调速从动齿轮	Driven gear, regulator	1	
16	25114/168F	调速飞块	Flying block	2	
17	25100/168F	调速从动齿轮组件	Driven gear assy, regulator	1	
18	25117/168F	调速轴卡圈	Snap ring	1	
19	25113/168F	调速滑套垫片	Washer	1	
20	25112/168F	调速滑套	Sliding sleeve	1	

E-2 曲轴箱盖组件 CRANKCASE COVER ASSY

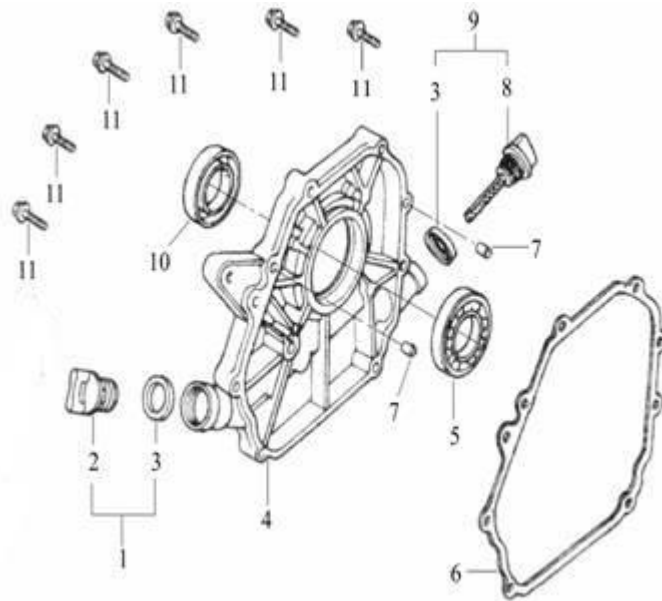

序号 S/N	零部件代号 Part No.	零部件名称	Description	数量 Quantity	备注 Remark
1	15520/168F	机油塞组件	Oil plug with Seal	1	
2	15521/168F	机油塞	Oil plug	1	
3	15512/168F	机油尺密封圈	Seal	2	
4	11211/168F	曲轴箱盖	Crankcase cover	1	
5	GB/T276	轴承 6205	Bearing 6205	1	
6	11114/168F	曲轴箱垫片	Gasket, crankcase	1	
7	11113/168F	定位销 $\phi 8 \times 14$	Set pin	2	
8	15511/168F	机油尺	Dipstick	1	
9	15510/168F	机油尺组件	Dipstick with seal	1	
10	11120/168F	曲轴油封组件	Oil seal, crankshaft	1	
11	GB/T16674.2	螺栓 M8 \times 32	Bolt M8 \times 32	6	

E-3 气缸头 气缸头盖总成 CYLINDER HEAD & CYLINDER HEAD COVER ASSY

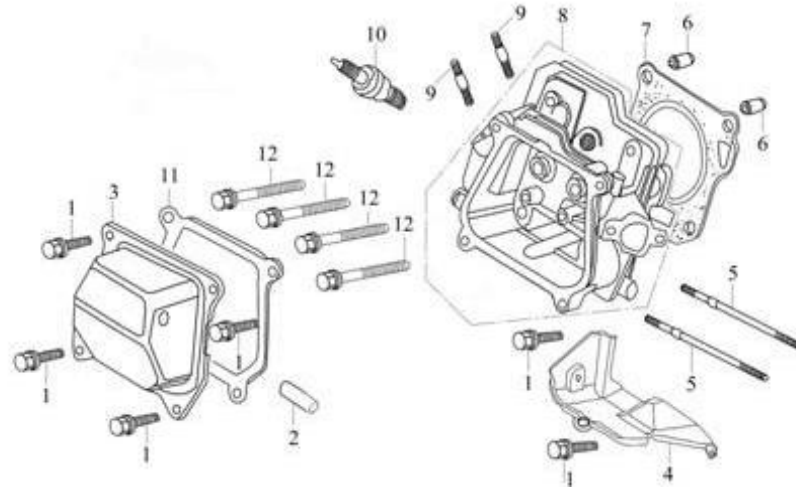

序号 S/N	零部件代号 Part No.	零部件名称	Description	数量 Quantity	备注 Remark
1	GB/T16674.2	螺栓 M6×12	Bolt M6×12	6	
2	19143	废气管	Air duck	1	
3	12200/168F	气缸头盖组合	Cylinder head cover Assy	1	
4	19112/168F	下导风罩	Lead wind cover	1	
5	17218/168F	进气口双头螺栓 M6×109	Stud M6×109	2	
6	12117/168F	气缸头定位销 φ10×16	Set pin φ10×16	2	
7	12121	气缸头密封垫片	Gasket, cylinder head	1	
8	12100	气缸头组合	Cylinder head Assy	1	
9	18214/168F	排气口双头螺栓 M8×34	Stud M8×34	2	
10	27100/168F	火花塞 F6TC	Spark plug F6TC	1	
11	12212/168F	气缸头盖密封圈	Gasket, cylinder head cover	1	
12	12118/168F	气缸头螺栓	Bolt	4	

E-4 曲轴 活塞连杆总成 CRANKSHAFT, PISTON & CONNECTING

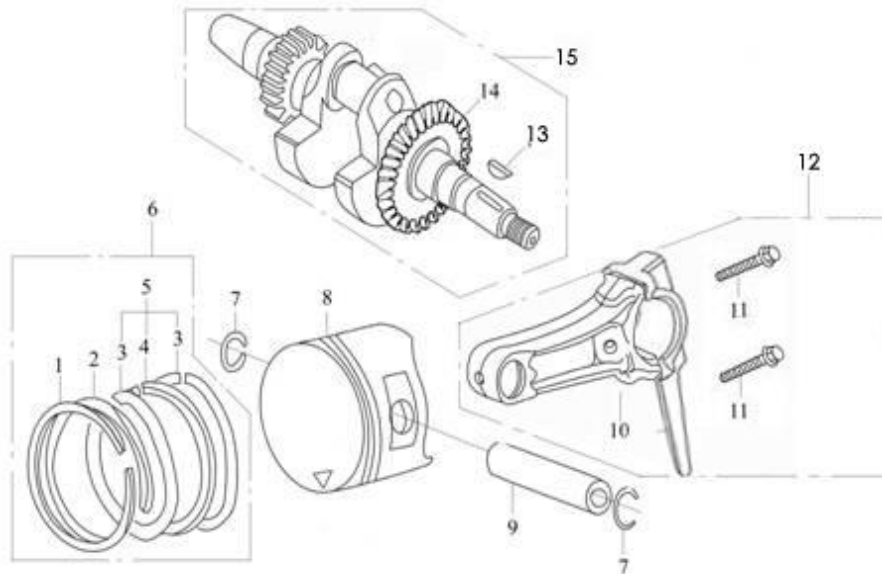

序号 S/N	零部件代号 Part No.	零部件名称	Description	数量 Quantity	备注 Remark
1	13411/168F	活塞环 (一)	Piston ring (I)	1	
2	13412/168F	活塞环 (二)	Piston ring (II)	1	
3	13422/168F	侧环	Side rail	2	
4	13421/168F	衬簧	Expander	1	
5	13420/168F	油环组件	Scrapper ring set	1	
6	13400/168F	活塞环组合	Piston ring assy	1	
7	13313/168F	活塞销挡圈	Piston pin circlip	2	
8	13311	活塞	Piston	1	
9	13312/168F	活塞销	Piston pin	1	
10	13211/168F	连杆	Shank	1	
11	13213/168F	连杆螺栓	Bolt	2	
12	13200/168F	连杆组合	Connecting rod assy	1	
13	13112/168F	半圆键	Woodruff key	1	

E-4 曲轴 活塞连杆总成 CRANKSHAFT, PISTON & CONNECTING

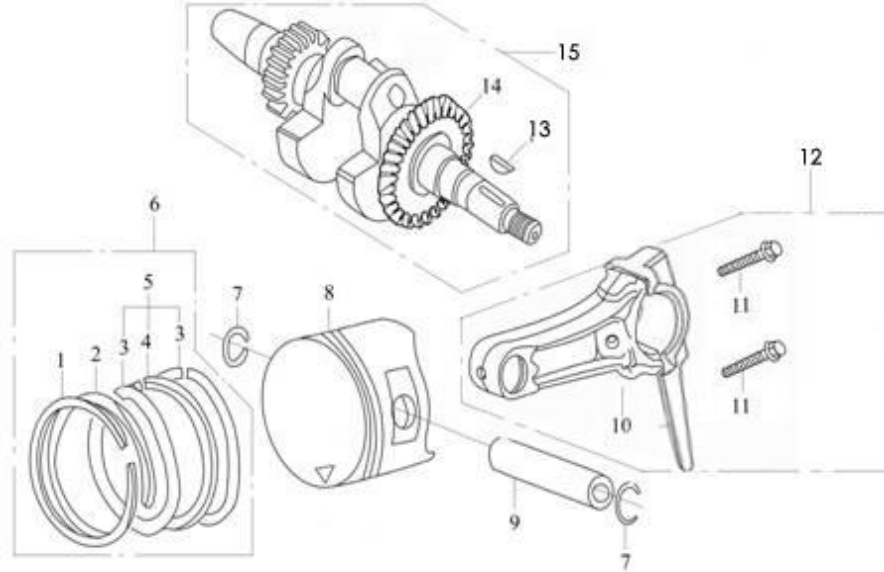

序号 S/N	零 部 件 代 号 Part No.	零 部 件 名 称	Description	数 量 Quantity	备 注 Remark
14	13111	曲轴	Crankshaft	1	
15	13100	曲轴组合	Crankshaft assy	1	

E-5 凸轮轴装配组合 气门摇臂组合 COMBINATION OF CAM SHAFT & VALVE ROCKER

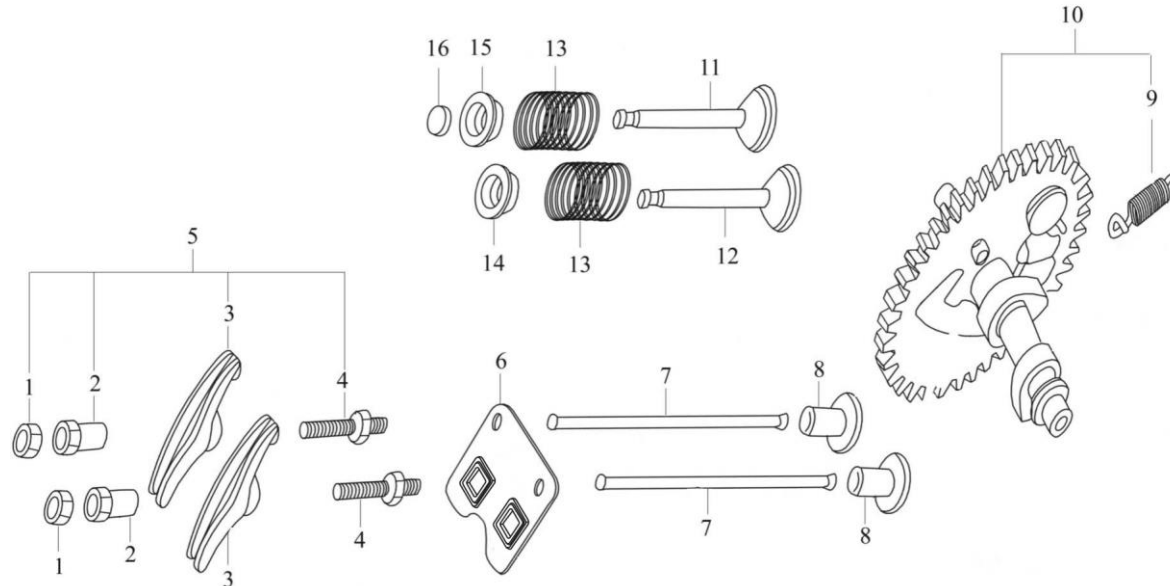

序号 S/N	零部件代号 Part No.	零部件名称	Description	数量 Quantity	备注 Remark
1	14314/168F	气门间隙调节螺母	Lock nut	2	
2	14312/168F	摇臂轴座销	Sleeve	2	
3	14311/168F	气门摇臂	Valve rocker	2	
4	14313/168F	气门间隙调节螺栓	Adjusting bolt for valve gap	2	
5	14310/168F	气门摇臂装配组合	Valve rocker assy	2	
6	14221/168F	推杆导架	Pusher guide	1	
7	14210/168F	推杆组件	Pusher	2	
8	14315	挺柱	Tappet	2	
9	14122/168F	甩块弹簧	Extension spring	1	
10	14100	凸轮轴装配组合	Camshaft Assy	1	
11	14412/168F	排气门	Exhaust valve	1	
12	14411/168F	进气门	Intake valve	1	

E-5 凸轮轴装配组合 气门摇臂组合 COMBINATION OF CAM SHAFT & VALVE ROCKER

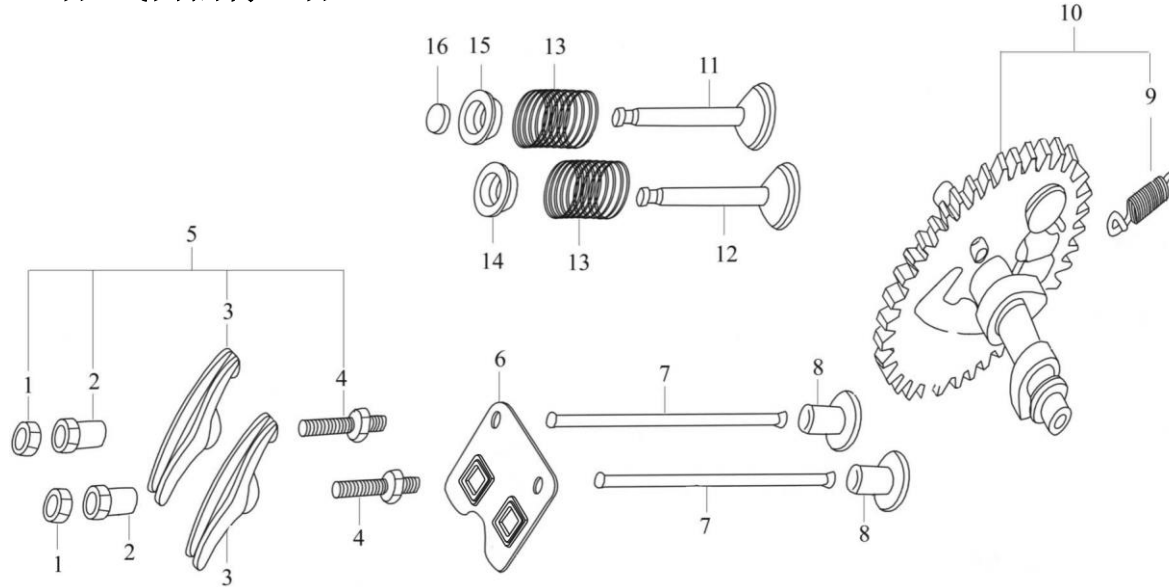

序号 S/N	零 部 件 代 号 Part No.	零 部 件 名 称	Description	数 量 Quantity	备 注 Remark
13	14414/168F	气门弹簧	Valve spring	2	
14	14413/168F	气门弹簧座 (一)	Spring seat, intake valve	1	
15	14415/168F	气门弹簧座 (二)	Spring seat, exhaust valve	1	
16	14416/168F	气门顶帽	Cap	1	

E-6 化油器总成 CARBURETOR ASSY

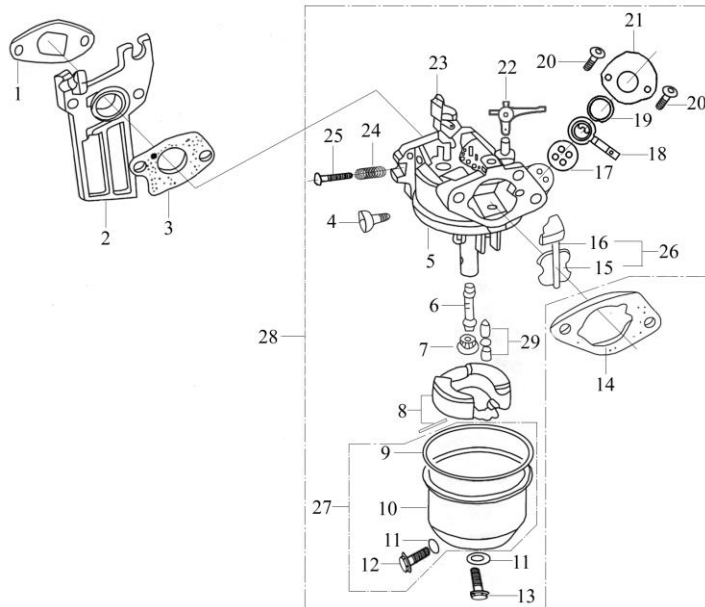

序号 S/N	零部件代号 Part No.	零部件名称	Description	数量 Quantity	备注 Remark
1	17219	进气口垫片	Inlet gasket	1	
2	16112/168F	化油器接块	Connecting block	1	
3	16113/168F	化油器垫片	Carburetor gasket	1	
4	16351	怠速调整螺钉	Idle adjustment screw	1	
5	16240	化油器本体	Mixture chamber body	1	
6	16244	主喷油管	Main nozzle	1	
7	16243	主喷油孔	Main jet	1	
8	16220	浮子组件	Float	1	
9	16216	浮子室密封垫	Float chamber gasket	1	
10	16211	浮子室	Float chamber	1	
11	16215	浮子室放油螺钉密封垫	Washer	2	
12	16214	浮子室放油螺钉	Float chamber drain Screw	1	
13	16212	浮子室螺钉	Screw	1	
14	17113	空滤器垫片	Air cleaner gasket	1	

E-6 化油器总成 CARBURETOR ASSY

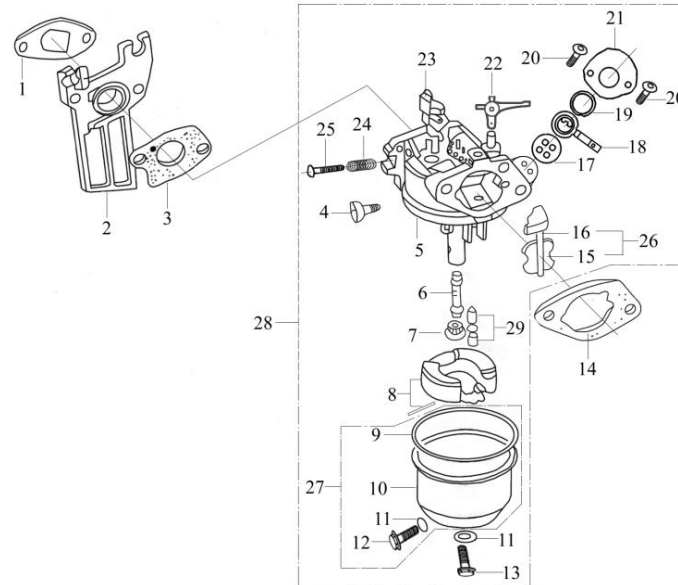

序号 S/N	零部件代号 Part No.	零部件名称	Description	数量 Quantity	备注 Remark
15	16321	阻风门	Choke	1	
16	16322	阻风门轴	Choke stem	1	
17	16364	化油器开关密封圈	Airproof washer	1	
18	16363	化油器开关手柄	Throttle lever	1	
19	16368	化油器开关密封圈	Washer	1	
20	16367	化油器开关盖螺钉	Screw M4	2	
21	16362	化油器开关盖	Cover	1	
22	16114/168F	阻风门开关	Choke switch	1	
23	16250	节气门组合	Throttle unit	1	
24	16332	混合比调整螺钉弹簧	Spring, mixture adjustment screw	1	
25	16331	混合比调整螺钉	Mixture adjustment screw	1	
26	16320	阻风门组合	Choke unit	1	
27	16210	浮子室组件	Float chamber	1	
28	16100	化油器总成	Carburetor Assy	1	
29	16230	浮子油针组合	Float needle	1	

E-7 燃油箱组成 FUEL TANK ASS

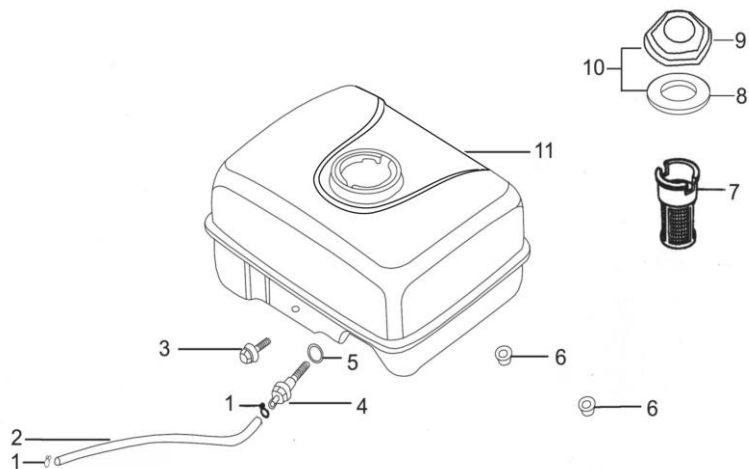

序号 S/N	零部件代号 Part No.	零部件名称	Description	数量 Quantity	备注 Remark
1	16622/168F	油管夹	Pipe clamp	2	
2	16621/168F	出油管	Outlet pipe	1	
3	GB/T16674.2	螺栓 M6×25	Bolt M6×25	1	
4	16630/168F	出油接头	Connector	1	
5	16634/168F	出油接头密封垫	Packing ring	1	
6	GB/T6186	自锁螺母 M6	Nut M6	2	
7	16610/168F	过滤杯组件	Filter cup	1	
8	16414/168F	燃油箱盖密封圈	Packing ring	1	
9	16411/168F	燃油箱盖	Fuel filler cap	1	
10	16400/168F	燃油箱盖组合	Fuel filler cap with packing ring	1	
11	16500/168F	燃油箱组合	Fuel tank	1	

E-8 空气滤清器总成 AIR CLEANER ASSY

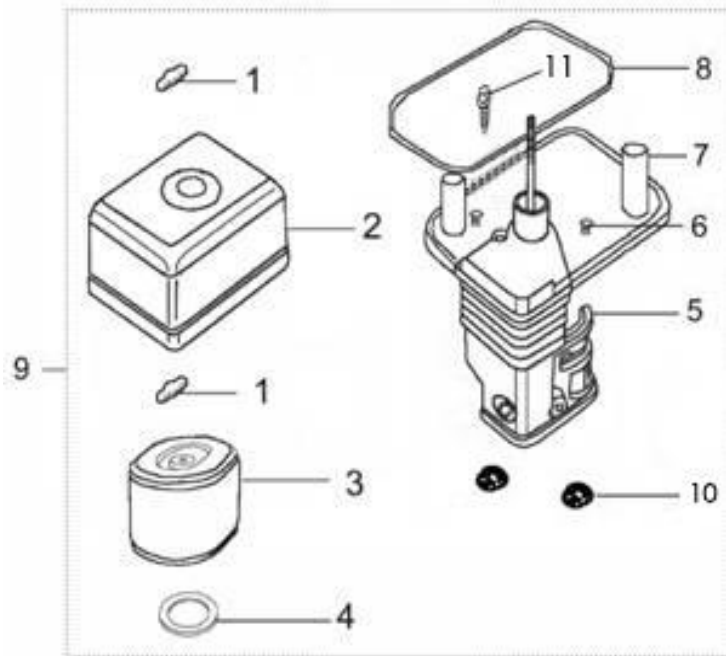

序号 S/N	零部件代号 Part No	零部件名称	Description	数量 Quantity	备注 Remark
1	17111/168F	空滤器盖螺母	Wing nut	2	
2	17112/168F	空滤器盖	Air cleaner cover	1	
3	17126/168F	空滤器滤芯 (单体)	Filter element	1	
4	17121/168F	空滤器垫圈	Washer	1	
5	17200/168F	进气管组合	Air cleaner housing	1	
6	GB/T3115	螺钉 M5×12	Screw M5×12	2	
7	17114/168F	空滤器本体	Air cleaner base	1	
8	17127/168F	密封圈 (大)	Gasket	1	
9	17100/168F	空滤器总成	Air cleaner assy	1	
10	GB/T6187	螺母 M6 (法兰锁紧)	Nut M6	2	
11	GB/T16674.2	螺钉 M6×22	Screw M6×22	1	

E-9 消声器组件 MUFFLER

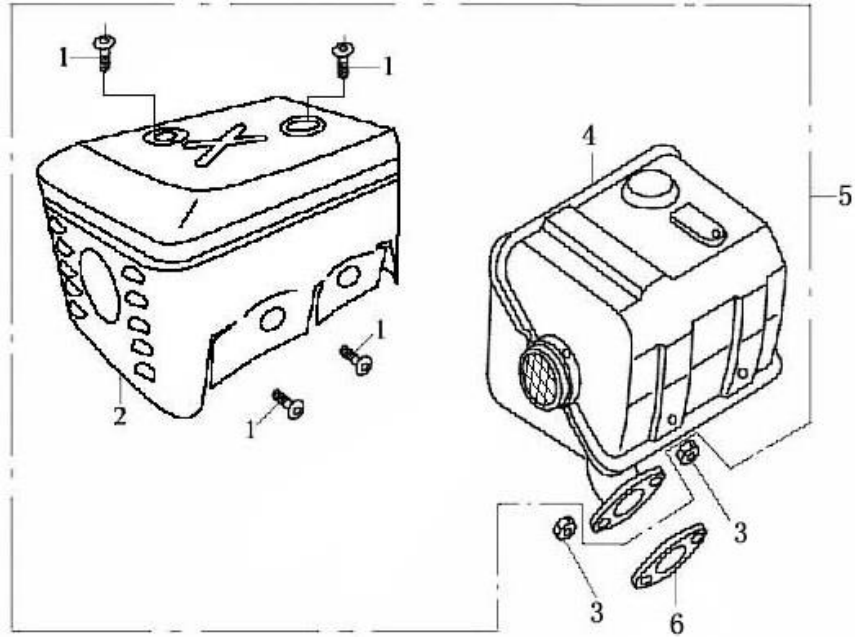

序号 S/N	零部件代号 Part No	零部件名称	Description	数量 Quantity	备注 Remark
1	GB/T16674.2	螺钉 M5×8	Screw M5×8	4	
2	18200/168F	消声器护罩组合	Muffler hood	1	
3	GB/T6170	螺母 M8	Nut M8	2	
4	18100/168F	消声器内胆组合	Muffler	1	
5	18000/168F	消声器总成	Exhaust muffler	1	
6	18215/168F	排气口垫片	Exhaust gasket	1	

E-10 反冲启动器部件 RECOIL STARTER

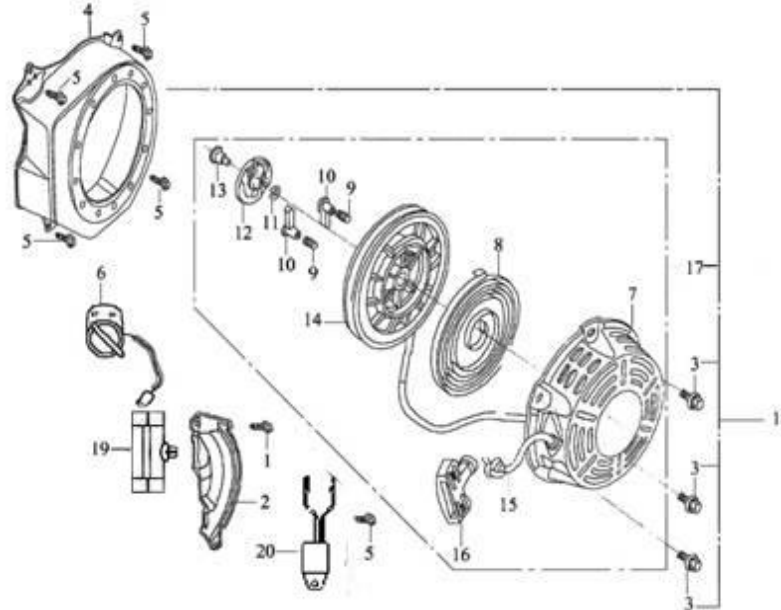

序号 S/N	零部件代号 Part No	零部件名称	Description	数量 Quantity	备注 Remark
1	GB/T16674.2	螺栓 M6×22	Bolt M6×22	1	
2	19300/168F	曲轴箱侧板焊接组合	Crankcase side plate assy	1	
3	GB/T16674.2	螺栓 M6×8	Bolt M6×8	3	
4	19200	风扇罩组合	Fan hood assy	1	
5	GB/T16674.2	螺栓 M6×12	Bolt M6×12	5	
6	27300/168F	熄火开关组合	Engine switch	1	
7	23200/168F	反冲启动器外壳组合	Casing	1	
8	23114/168F	盘簧	Spiral spring	1	
9	23112/168F	棘爪弹簧	Ratchet spring	2	
10	23115/168F	棘爪	Ratchet	2	
11	23111/168F	摩擦弹簧	Friction spring	1	
12	23116/168F	弹簧盖	Spring lid	1	

E-10 反冲起动器部件 RECOIL STARTER

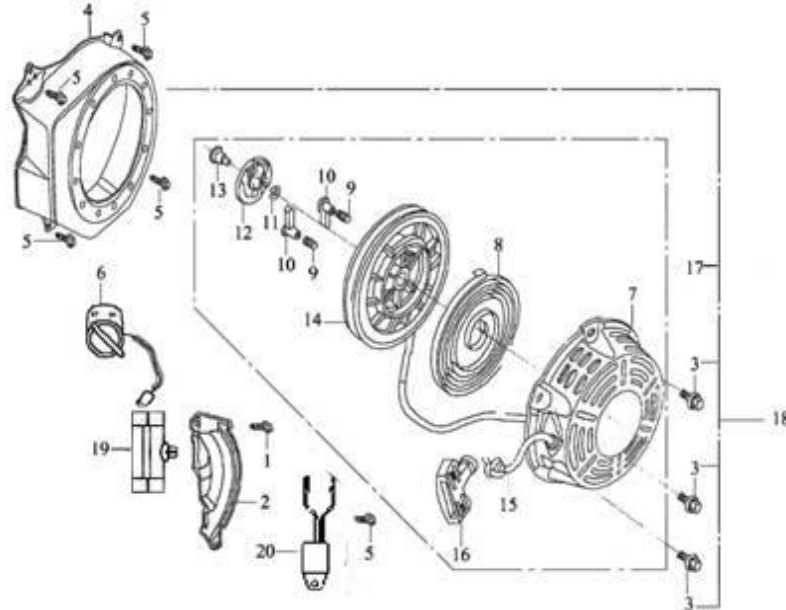

序号 S/N	零 部 件 代 号 Part No	零 部 件 名 称	Description	数 量 Quantity	备 注 Remark
13	23113/168F	轴位螺钉	Set screw	1	
14	23117/168F	起动器卷轴	Starter rolls	1	
15	23118/168F	拉绳	Rope	1	
16	23121/168F	拉手	Pulling handle	1	
17	23100	反冲起动器	Recoil starter	1	
18	27100	反冲起动器总成	Recoil starter assy	1	
19	19313/168F	接线盒	Plastic clip	1	
20	27500/168F	单向导通器组合	Diode	1	

E-11 调速控制系统 REGULATING CONTROL SYSTEM

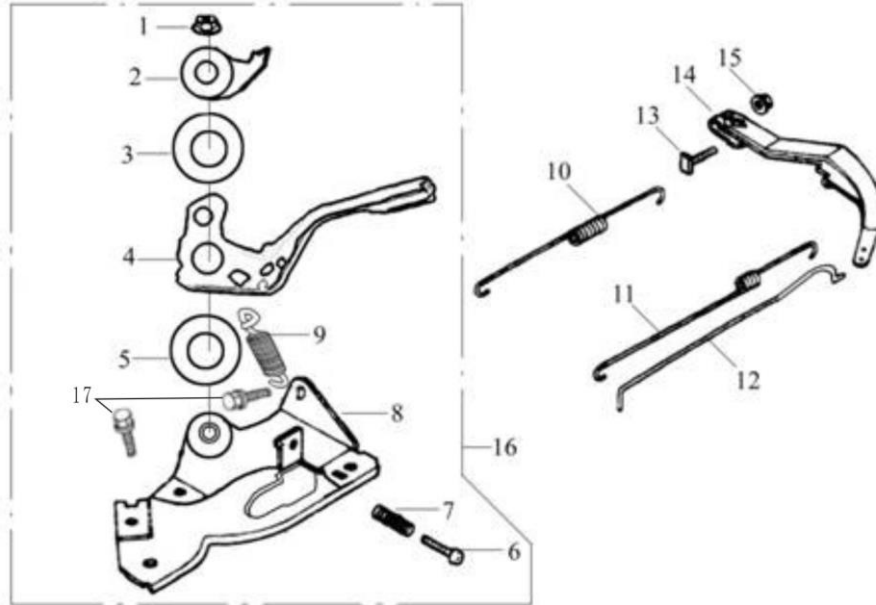

序号 S/N	零 部 件 代 号 Part No	零 部 件 名 称	Description	数 量 Quantity	备 注 Remark
1	GB/T6186	自锁螺母 M6	Nut M6	1	
2	26224/168F	定位板	Setting panel	1	
3	26223/168F	弹簧片	Spring patch	1	
4	26221/168F	转速控制臂	Handgrip	1	
5	26222/168F	垫片	Washer	1	
6	GB/T818-85-H	螺栓 M5×25	Bolt M5×25	1	
7	26215/168F	调速弹簧	Regulating spring	1	
8	26210/168F	调速支撑板组件	Support panel assy	1	
9	26214/168F	拉簧	Spring	1	
10	26117/168F	复位弹簧	Back spring	1	
11	26118/168F	微调速弹簧	Fine regulating spring	1	

E-11 调速控制系统 REGULATING CONTROL SYSTEM

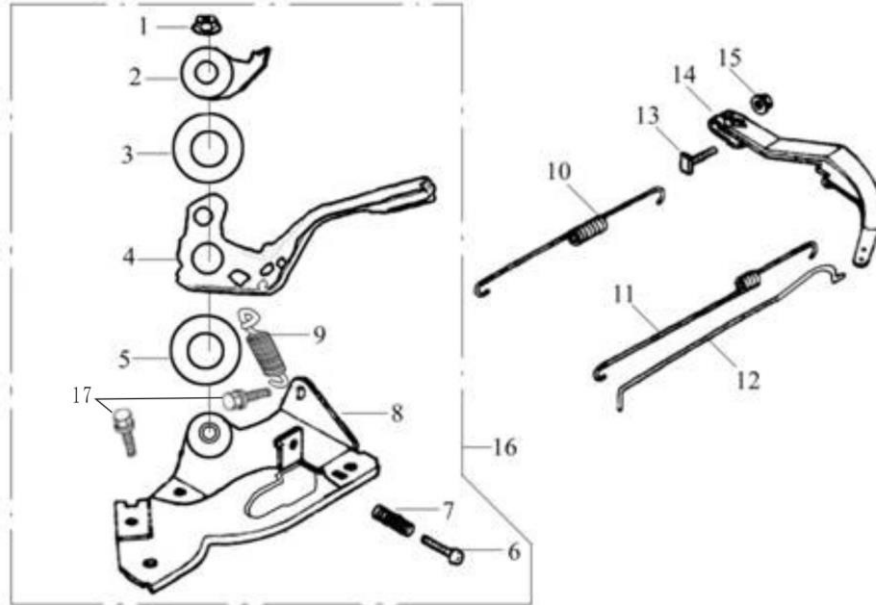

序号 S/N	零部件代号 Part No	零部件名称	Description	数量 Quantity	备注 Remark
12	26115/168F	调速拉杆	Pulling rod	1	
13	26116/168F	调速臂紧固螺栓	Lock bolt	1	
14	26114/168F	调速臂	Regulating arm	1	
15	GB6187	螺母 M6 (法兰锁紧)	Nut M6	1	
16	26200/168F	调速支架组合	Regulating frame assy	1	
17	GB/T16674.2	螺栓 M6×12	Bolt M6×12	2	

E-12 飞轮部件 FLYWHEEL

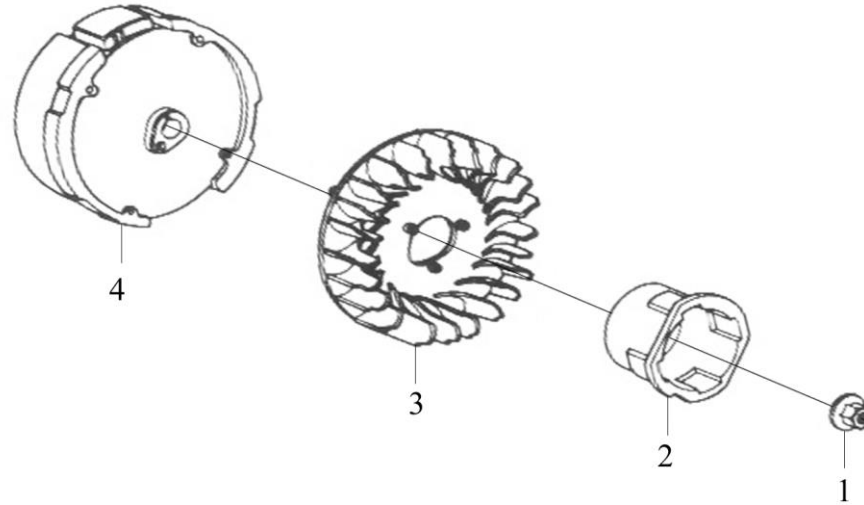

序号 S/N	零 部 件 代 号 Part No	零 部 件 名 称	Description	数 量 Quantity	备 注 Remark
1	23317	飞轮螺母 M14×1.5	Nut M14×1.5	1	
2	23316/168F	起动套	Starting flange	1	
3	19111/168F	飞轮风扇	Flywheel fan	1	
4	23300/168F	飞轮组合	Flywheel	1	

E-13 点火线圈组件 IGNITION COIL

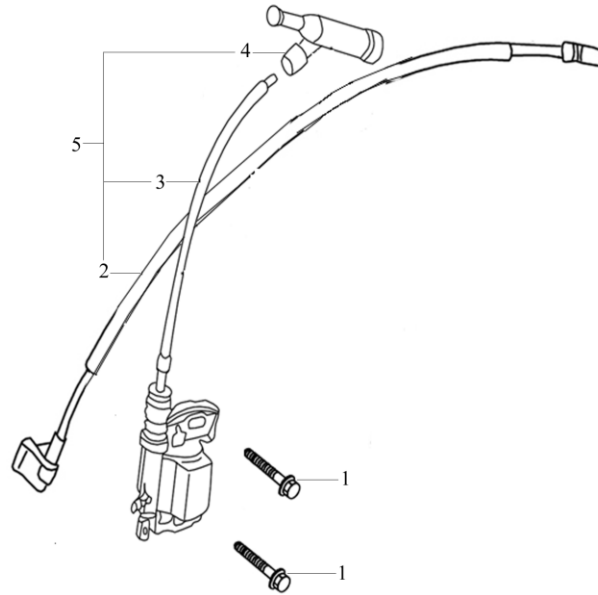

序号 S/N	零部件代号 Part No	零部件名称	Description	数量 Quantity	备注 Remark
1	GB/T16674.2	螺钉 M6×22	Screw M6×22	2	
2	27230/168F	熄火线组件	Engine stop cable	1	
3	27200/168F	点火线圈	Ignition coil	1	
4	27220/168F	火花塞帽组件	Spark plug cap	1	
5	27210/168F	点火线圈组件	Ignition coil assy	1	

E-14 贴花 EMBLEM



序号 S/N	零部件代号 Part No	零部件名称	Description	数量 Quantity	备注 Remark
1	91139	注意贮存贴花	Emblem, Notice: store	1	
2	91111	型号贴花	Model label	1	
3	91114/168F	龟兔贴花	Emblem, tortoise and rabbit	1	
4	91112/168F	加注机油贴花	Emblem, adding oil	1	
5	91115/168F	阻风门开关贴花	Emblem, choke lever	1	
6	91113/168F	空滤器保养贴花	Emblem, maintenance of air cleaner	1	
7	91118/168F	注意警告贴花	Emblem, Note or Warning	1	